

Evaluation of electric propulsion system in terms of fuel consumption

Hiroyasu Kifune

Tokyo university of Marine Science and Technology

1. Introduction

In general, the electric propulsion system has been discussed and evaluated from various viewpoints, for example, fuel saving effect, decreasing sound noise for crew and passenger, optimizing engine room space for making cargo space bigger, improving redundancy of navigation, reducing maintenance work, and suppressing initial cost. After dual fuel engine was developed for 2 cycle marine diesel engine, the electric propulsion has gone to second position or less because of fuel economy and initial cost, especially for merchant cargo ship. On the other hand, it is inevitable system for large cruise liner due to low vibration, low noise, high redundancy, and large hotel load. Recently, autonomous navigation technology has become attractive themes for not only car industry but also marine sector. A part of engineers believe that the electric propulsion system is necessary to realize it. However, it is hard to find reasonable discussions why the electric propulsion is in main stream of the autonomous vessel. Many topics to be discussed has appeared and disappeared in our marine sector.

Before talking about new topics for clean future of marine industry and our world, it is effective to make sure that what we can expect for the electric propulsion system, and what have to be

done. This paper focus on the energy saving effect of the electric propulsion system for large vessel so that we know how to design the future better. Small boats are not in main theme in this paper.

2. Definitions

The electric propulsion system provides SHP (shaft horse power) by using electric motor for driving main thruster including FPP, CPP, and pump jet. In general, the electric propulsion system is classified to diesel electric system using diesel gensets, battery propulsion system using secondary lithium ion battery, and hybrid propulsion system. Candidate of energy sources of the hybrid propulsion system are main diesel engine, diesel gensets, secondary battery, fuel cell, and auxiliary generators taking power from exhaust gas thermal energy. There are some cases that combination of solar cell and secondary battery interconnects to AC line system which is provided by gensets ⁽¹⁾. However, such multi energy source AC grid system is out of scope in this paper because its system is not for the propulsion.

3. View from system configuration

3.1 AC bus system

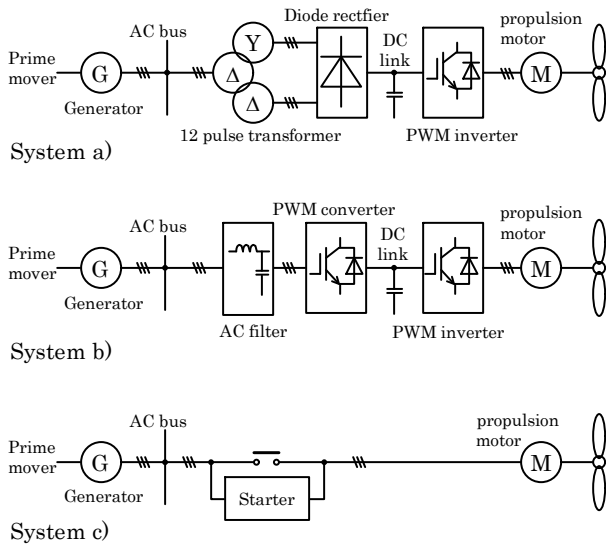

Fig.1 Electric propulsion system with AC bus

Fig.1 shows representative samples of the electric propulsion system which use AC bus mainly. The system a) to c) has DC link between power electric converters. However, it is sorted to AC bus system because the load which means inverter has only one power source which means rectifier in DC link.

The system a) consists of the electric motor, PWM inverter, diode rectifier, and 12-pulse transformer ⁽²⁾. The system b) has higher performance to suppress THD than system a) because PWM rectifier is equipped for PFC (power factor correction) operation ⁽³⁾. The systems of a) and b) can use not only CPP but also FPP, because shaft speed control is available by using power electronics converters. It is required to install a break resistor in DC connection point between the rectifier and the inverter for protecting inverter from back power in system a).

The system c) is most simple configuration, just uses a starter circuit. It can drive only CPP because the speed of electric motor cannot be changed for controlling SHP.

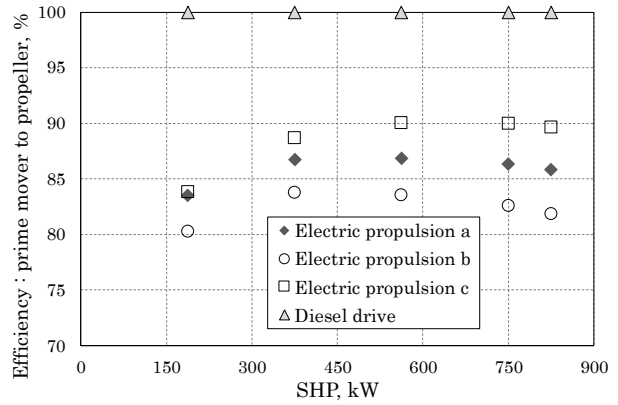

Fig.2 Estimated results of total efficiency from prime mover to propeller as diesel drive system's efficiency is 100%

3.2 Energy conversion loss

It is difficult to compare and to discuss the energy conversion loss in the propulsion systems shown in Fig.1 because each system tends to be applied to different power scale plant. For example, system a) is often used for large scale propulsion system like LNG carrier, large cruise liner, and ice-class cargo vessel. On the other hand, system d) is seemed to be used for middle to small cargo ship and research vessel less than several 1000 ton because it's difficult to install the panel of electric converters in the limited machinery space. In this paper, however, it is assumed that SHP is 750kW for comparing them. In addition, to make the discussion simple, this paper neglects the electric power of onboard load and side thrusters due to limitation of pages, although it is necessary to consider both of them for clarifying the electric propulsion system. To evaluate the energy conversion efficiency and their power loss from the power source to the propeller, a simulation scheme which has been developed by author's group was utilized.

Fig.2 shows the efficiency comparing to the conventional diesel drive propulsion system. The

system a) and b) uses FPP generally, system c) uses only CPP. Induction motor was applied to the main propulsion motor for driving propeller shaft in this simulation. PWM converter and inverter consist of 4 units which use IGBT (1200V/600A) at switching frequency 4kHz. AC grid voltage is 440V. Its power factor is assumed to be constant 0.8 regardless of the electric load condition.

As generally said, power dissipation is inevitable when the energy is delivered in the electric propulsion system because there are several energy conversion processes from the prime mover to the propeller. The system c) can maintain high efficiency comparing to other electric propulsion over middle SHP range due to less components in the propulsion system. However, when required SHP is low, advantage of system c) is decreased, because the efficiency of induction motor in system c) becomes lower than system a) and b). Power factor tends to be low in constant speed condition comparing to variable speed condition when the induction motor is operated in low load. Although AC line power factor is assumed to be constant in this simulation, in actual system c), it fluctuates depending on the load factor of the induction motor for propulsion. Fig.3 shows a sample data of measured power factor in actual electric propulsion ship which has same topology as system c). The simulation does not have a function to estimate the generator's efficiency in low power factor condition. However, it is nature to think that copper loss and iron loss increase in generators in low power factor condition because reactive current becomes large. It will be additional factor to decrease total efficiency of system c) from the prime mover to the propeller in low load condition.

The efficiency of system b) is lowest in whole SHP range. The reason that efficiency of system b) is low in low load condition is different from system c).

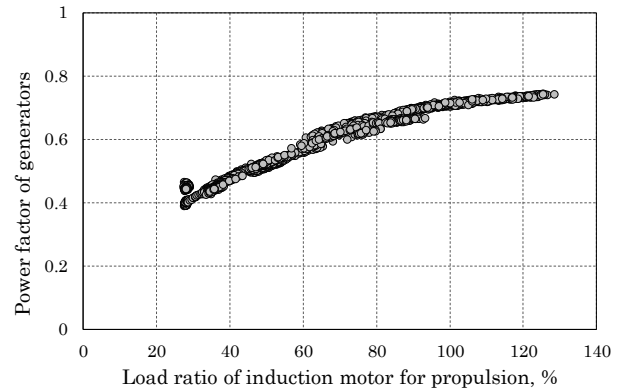

Fig.3 Sample of power factor to load ratio of propulsion motor measured by system c) in actual

In almost case, inverter and converter using IGBT have such a feature due to IGBT's saturation characteristics. If permanent-magnetic motor is used as the propulsion motor instead of the induction motor, the efficiency of system a) and b) can be improved by 1-2%.

In this paper, as mentioned above, onboard electric load and side thruster's load are neglected. Generally speaking, the electric propulsion system can save fuel consumption by controlling the number of diesel-gensets depending on load condition. If the number of genset are controlled appropriately and its effect reach to 10~15%, the electric propulsion system can be good candidate from the view point of reducing FOC and CO2 emission.

3.3 DC bus system

DC bus system has been attractive for vessels of marine research, marine resource investigation, and development because it is expected to reduce fuel consumption by controlling speed of diesel generators appropriately ⁽⁴⁾. But in this paper, prime mover's thermal efficiency is not included. In addition, other DC voltage source like battery and capacitor can be connected as the power source and/or energy buffer ⁽⁵⁾. Furthermore, DC bus has several power sources and/or several loads in

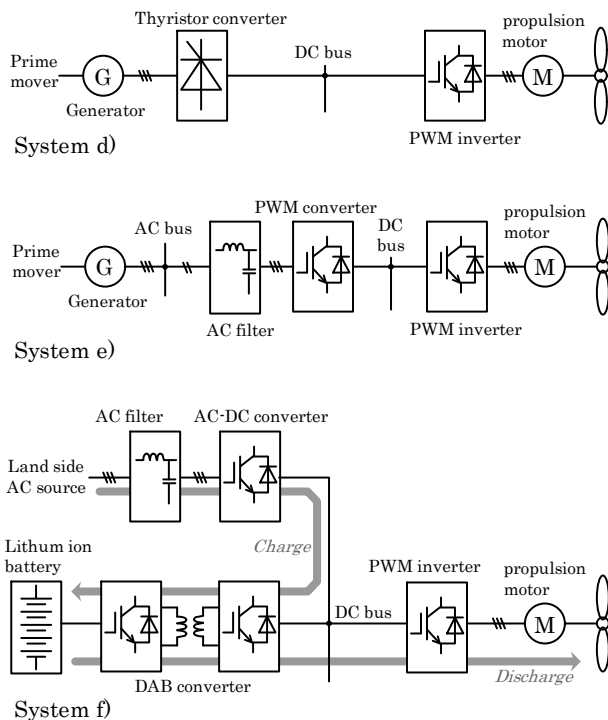

Fig.4 Electric propulsion system with DC bus

parallel. To simplify the discussion, however, this paper assumes three types of the electric propulsion systems using DC bus shown in Fig.4. The induction motor is applied as the propulsor motor.

In system d), thyristor converter control DC bus voltage. In output side of generator, THD tends to be large when the load ratio is low. However, it does not affect any other electric machine because generator's load is only the thyristor converter. System e) is similar topology as system b). It has DC bus to be connected to several DC power sources and/or several PWM inverters as electric load ⁽⁶⁾. System f) is often said as battery propulsion system which uses AC power source of land side for charging onboard battery ⁽⁷⁾.

To compare these systems from the view point of energy consumption, the simulation was implemented. DC bus voltage was set to 690V. The land side AC was assumed to be 440V/60Hz. In system d), it is often used variable speed diesel-gensets as mentioned before. Therefore,

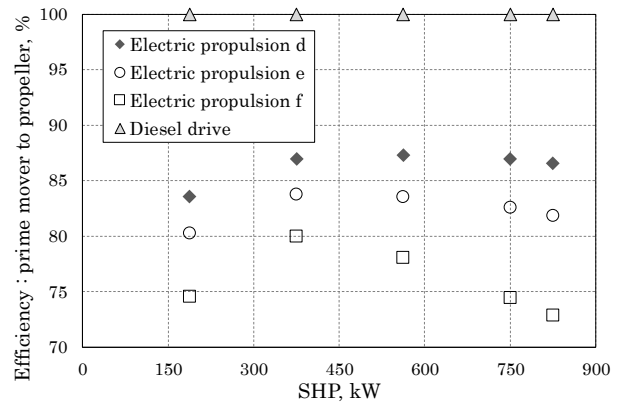

Fig.5 Estimated results of total efficiency from prime mover or AC line to propeller as diesel drive system's efficiency is 100%

there is possibility to improve its total efficiency including the prime mover comparing to other systems. The total efficiency of system e) is same as system b) because the topology is same in this simulation. In system f), the energy flows through lots of devices. The electric power from land side AC line is delivered to the battery through AC line filter, PWM converter, and dual active bridge type DC-DC converter when the battery is charged. Then, the battery power is delivered to the propeller through DC-DC converter, PWM inverter, and induction motor. Hence, its total efficiency from AC power source of land side to the propeller becomes lower inevitably. Additionally, this simulation result does not include efficiency of lithium ion battery. The battery gets warm when the battery is charged and discharged because of internal impedance. In general, it is often said that charge/discharge efficiency of lithium ion battery is over 95%. But it is not 100%. Thus, there is possibility that the total efficiency of system f) will get worse.

4. View from propeller

4.1 Efficiency of propeller

Talking about the propulsion system, almost all discussion is based on SHP which is provided by

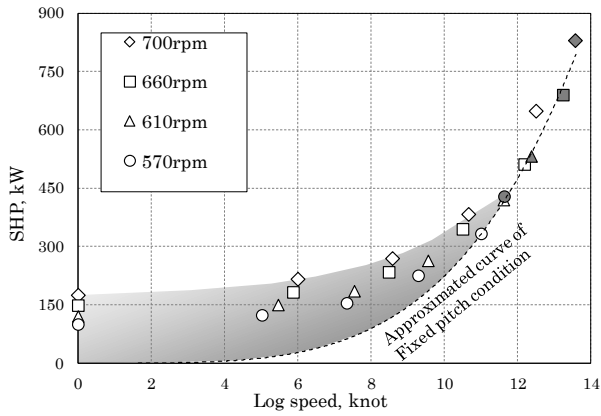

Fig.6 Sample measured data of SHP to log speed in ship equipped with CPP

the electric motor or the engine to the propeller ⁽⁸⁾⁽⁹⁾. However, those discussions may have no outstanding characteristics comparing to the propeller's one. Fig.6 is a sample of measured data which shows relation between SHP and log speed in actual sea condition. The propeller speed and pitch angle of CPP were changed as the parameter. CPP consumes certain energy even if the ship speed is zero unlike FPP. As is clear from the figure, power dissipation which is not converted to the thrust becomes over 100kW. As far as author's group investigated, around 15% of maximum SHP is wasted in low speed condition which shows hatched area in the figure. It can be said that the thrust force of CPP is controlled by changing not input SHP but its efficiency. This is not small issue for the electric propulsion system because low speed condition is frequently used in the electric propulsion ship due to operations of dynamic positioning, marine investigation, and off-shore engineering.

4.2 Load fluctuation

Fig.7 shows a sample data of the propulsion motor power in system c) when the ship went rough sea condition (see Table 1). CPP is driven by the induction motor in almost constant speed. The

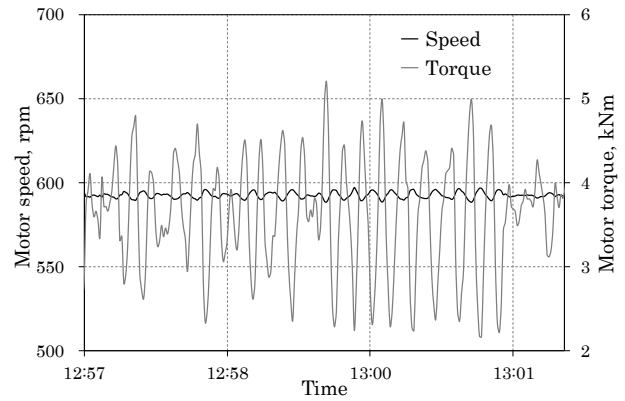

Fig.7 State of one propulsion motor driving CPP in rough sea condition

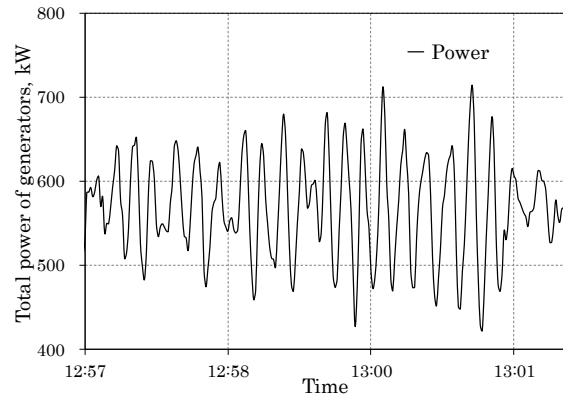

Fig.8 Total power of generators in rough sea condition

motor power is fluctuated largely because the motor torque is varied cyclic. Torque is affected by

Table 1 Environment condition

Measured item		Value
Wind (relative)	Speed	15.0 m/s
	Direction	255 °
Wave (relative)	Height	6.0 m
	Cycle	17.5 sec
	Direction	249 °

Table 2 FOC at different sea condition

Sea condition	Measured FOC
Calm	160.6 l/h
Rough sea	193.0 l/h

the depth of CPP from sea surface changing by the wave which the ship encountered.

Total required power of diesel generators is also fluctuated (see Fig.8). When the load is changed rapidly and widely, turbo charger speed does not follow to the required level sufficiently. Inlet boost pressure cannot reach to appropriate level, then the engine speed comes down. For keeping the engine speed and frequency of generator to constant, amount of fuel injection is increased. As the result, the thermal efficiency of diesel engine gets worse and FOC is increased (see Table 2).

On the other hand, if the inverter is adopted to the electric propulsion system like system a), b), d), e), and f), the power of propulsion motor can be controlled to be constant. Load ratio of diesel generators is not affected by sea condition. Therefore, it is nature to think that the thermal efficiency of diesel engine becomes close to ideal state which is like shop trial data provided in the finished drawing book. Consequently, the inverter driven electric propulsion systems may have a benefit to control fuel consumption comparing to CPP propulsion system, in frequently load fluctuating condition like going in rough sea.

5. Summary

When the propulsion system is discussed for saving fuel, it is necessary to consider not only electric devices but also the power source and the propeller. The thermal efficiency diesel engines are different in constant-speed/variable-torque operation and variable-speed/variable-torque operation, even if the rated power is same.

Total efficiency of battery propulsion system depends on the type of electric power plant. If the land side of AC power is supplied by only renewable energy source, it will be good solution for reducing CO2 emission from vessel and society. But if the energy source depends on fossil fuel like Japan, the society's overall CO2 emission will

increase. The total efficiency of battery propulsion system including power plant efficiency is not attractive comparing to other type of the electric propulsion. Of course, it is non-sense to increase the nuclear power plant to supply the electric power to the battery propulsion system for reducing CO2 emission in only marine industry.

In this paper, the induction motor is adopted as the propulsion motor in all system. However, if permanent-magnetic motor is used as the propulsion motor instead of the induction motor, the efficiency of systems a), b), d), e), and f) can be improved by 1-2%.

Reference

- (1) MOL home page, "ISHIN-I The World's First Hybrid Car Carrier, Emerald Ace",
- (2) ABB home page, "Propulsion and thruster for shuttle and service vessels: redundant concept"
- (3) Niigata Power System home page, "Supply records – Ginga"
- (4) Asgeir J. Sørensen, and et.al., "Toward Safer, Smarter, and Greener Ships", IEEE Electrification Magazine / september 2017, pp.68-73, 2017
- (5) ABB home page, "Onboard DC Grid"
- (6) Danfoss home page, "Danfoss powers Asia's first E-ferry in Taiwan"
- (7) Siemens home page, "Siemens proves pioneer position delivering green solutions in the shipbuilding industry"
- (8) Hiroyasu Kifune, and et.al. "A Study of Fuel Consumption Model Using Tugboat's Propulsion System", Journal of JIME, Vol.50, No.4, pp.129-136, 2015
- (9) Gonzalez Jose, and et.al. "Tug boat propulsion system design and optimization", Proc. of 11th Int. Symposium. on Marine Engineering, Tokyo/Japan, B08-211, pp.314-320, Oct. 2017